

Win-Dor

T H E C A S E M E N T H A R D W A R E C O M P A N Y



Win-Dor

THE CASEMENT HARDWARE COMPANY

Factory and General Offices: 406 N. Wood St., Chicago, Ill.
U. S. A.

PRODUCTS { A complete correlated line of tested devices for installing, operating, and controlling wood and metal casement windows.

THE COMPANY: Originators and pioneer manufacturers of American casement hardware, the Company has been closely identified with the growing popularity of casement windows during the past thirty-one years. During this period Win-Dor developments have accounted for the major improvements in the art of casement operation and control.

EXPERIENCE: Over 200 thousand buildings equipped with Win-Dor devices serve as the greatest experience base in this field. The benefits of this wide and diversified experience contribute greatly to the superior performance and greater life characteristic of Win-Dor products.

SAFETY FACTOR CONSTRUCTION: Design and standards being based on ample experience rather than theoretical calculation accounts for the ability of Win-Dor devices to operate satisfactorily under severe conditions and stand up against abuse. (To withstand strains frequently encountered in actual use, casement operators require 100% more strength than indicated necessary for "normal" function of such devices.)

MANUFACTURING FACILITIES: A modern plant located in the convenient west side manufacturing district of Chicago gives facilities for efficient manufacture and prompt service for all territories.

COST: Specialization and volume permit manufacturing efficiencies which largely absorb the cost of more expensive materials. Important further savings in final costs to users are made by "fool-proof" simplification of installation features (reversibility-attaching tolerances, etc.).

DISTRIBUTION: Products for Wood Sash: Distributed nationally through builders' hardware dealers in all major market centers. Most of these maintain stocks and all receive direct service from the factory on contract requirements. In smaller towns, through retail hardware and lumber dealers served by strategically located jobbers stocks.

Devices for Steel Sash: Win-Dor Series 28 operators (page 9) are applicable to most American light section casements and to all intermediate types. Win-Dor Series 32 operators (Page 10) are for all oversize and heavy casements. Several manufacturers will supply Win-Dor on specification at a very slight extra over their own production standard equipment.

NOTE: The Company **does not** duplicate Win-Dor devices for sale under private marks of sash manufacturers or distributors.

IDENTIFICATION: For protection of specifiers and users, the mark Win-Dor is stamped on all products and labeled on all containers.

WARRANTY: Specific warranties are given for each Win-Dor device on the following pages. Written warranty is gladly furnished for any project on request.

REPRESENTATIVES

Branch: 101 Park Avenue, New York, N. Y.

C. E. Harris Co.
99 Bedford St.
Boston, Mass.

Franks-North Co.
4171 Flad Ave.
St. Louis, Mo.

W. H. Steele Co.
443 S. San Pedro St.
Los Angeles, Cal.

C. I. Yates
7 Front St.
San Francisco, Cal.

C. A. King
Terminal Sales Bldg.
Seattle, Wash.

Member: Producers' Council

Exhibits: Arch. Sample Corp., New York, and at the factory, 406 N. Wood Street, Chicago, Ill.

THIS IS WIN-DOR *Catalog* NO. 24 FOR 1938

**CORRELATED HARDWARE FOR WOOD
CASEMENT WINDOWS**

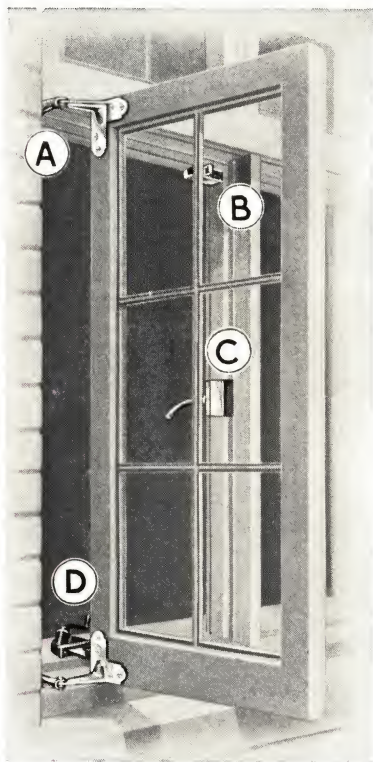

Satisfactory wood case-
ment window
installation depends almost en-
tirely upon the hardware used to
install, operate, and control the
sash. Hinges, handles, closing
and locking devices should be a
combination of efficient units de-
signed for smooth, trouble-free
usage. Such an arrangement of
correlated hardware may be ob-
tained by the use of Win-Dor
hardware as illustrated in the ac-
companying pictures. They show
inside and outside views of Win-
Dor hardware installed.
(See page 10 for Win-Dor matched
hardware set).

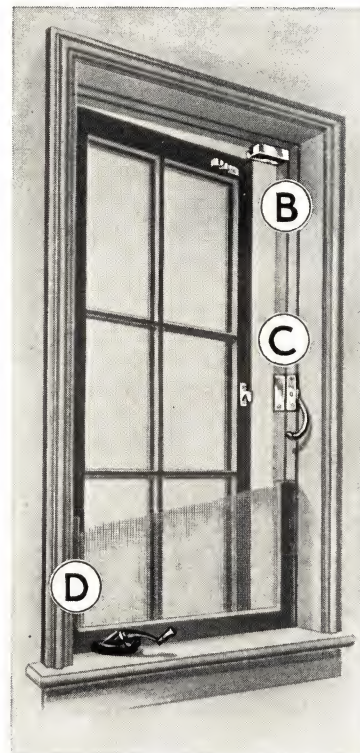

BY **Win-Dor**
TRADE MARK



The left hand illustration above shows Win-Dor Series 75 extension cleaning hinges for installing outswung wood casement windows. Extension hinges provide space between the frame and the sash for washing the outside of the window from the inside. Casement window hinges are described on Page 7.



Both the inside and outside views of the window show this Win-Dor Series 800 locking handle installed at the center of the casement. For manual locking, this handle is practical and convenient, as it works around the screen, permitting the casement to be locked without removing the screen. Series 800 handle is illustrated and described on page 8.



This is Win-Dor Series 45 top-closer. It is shown on both inside and outside views above and described on page 8. It is used for tight closing of the casement at the top opposite the hinge side. The top-closer does this automatically in conjunction with the operator used on the sill at the bottom of the window.



For the actual operation of the casement several types of Win-Dor operators are shown in this catalog. They work through-the-screen and automatically lock, open and close casements with the minimum effort. Win-Dor operators are illustrated with description and recommendations on pages 3, 4, 5, 6, 9 and 10.

THE CASEMENT HARDWARE CO.

Win-Dor

SERIES 26 OPERATOR

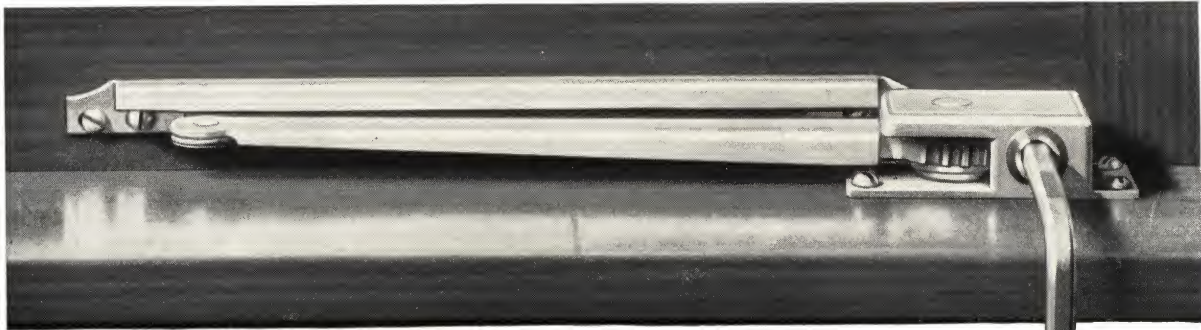

This is the accepted standard for casement window operators and over a quarter of a million are in use today. The performance record of this operator proves the quality and merit of Win-Dor hardware. Series 26 operator is reversible. It is worm and gear type and works through the screen. The case is interlocking of double wall construction providing a bearing seat of exceptional strength for large $\frac{3}{4}$ -inch naval bronze worm which is used with machine-cut carbon steel gear interlocked (without rivets) to the arm. Standard operator is furnished in steel, cadmium plated, or may be had in solid brass with monel metal, or high strength silicon bronze gear segment.

A Here is one of two critical parts in an operator. It is where the greatest strain occurs and, therefore, where the strongest construction should be. We anticipate far greater stress than will ever be applied by using a large $\frac{3}{4}$ inch naval bronze self-cleaning and anti-freezing worm strongly held in the housing.

B Another critical part. As the full pressure of the sash is applied to the arm, the gear must be capable of abuse, so Win-Dor uses a machine cut, heat treated gear of $\frac{3}{4}$ inch thickness interlocked (without rivets) to the arm.

C Neither rust nor other atmospheric conditions will attack and destroy this tension spring (which slides in the operator channel) because it is made of bronze.

D Handle stock is of $\frac{5}{16}$ inch rounded special section cold rolled steel, fitting snugly in the worm seat with a bearing length of $\frac{3}{4}$ inch.

E At this point, we use bronze again for a bushing through which the rivet is placed that holds the operator arm solidly in the housing.

F Handles for Series 26 and Series 30 operators are all equipped with accurately machined roller knobs.

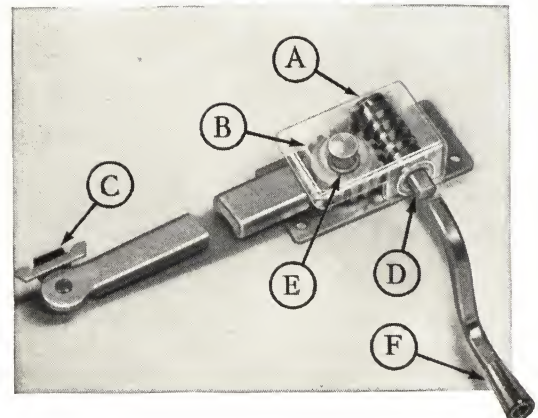

SERIES 30 OPERATOR



Similar in construction to Series 26 illustrated above, this operator is designed for narrow frames. It is reversible. It is made with $\frac{3}{4}$ -inch naval bronze worm, machine-cut gear segment, interlocked to arm, as illustrated on the right. Patented Win-Dor sash channel is part of the operator, together with extruded handle and solid brass roller grip. See details on page 4 for clearances for the Series 30 operator as well as recommendations for installation and catalog data.

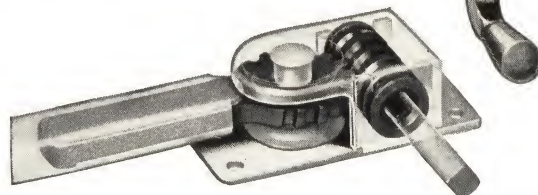

THE CASEMENT HARDWARE CO.

SERIES 26 RECOMMENDATIONS

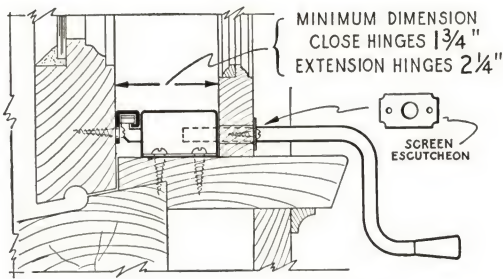

VERTICAL SECTION SCALE 3"-1"

The above detail shows typical installation of Series 26 operator with removable handle in place through wood frame screen.

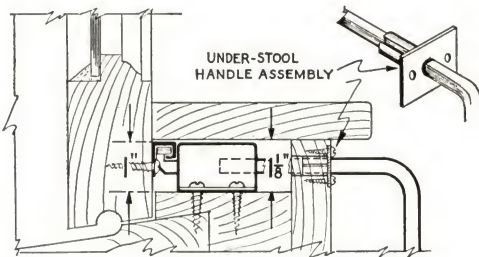

This detail shows understool construction with operator concealed and handle projecting through apron under the stool.

may be specified with complete assurance of satisfactory performance and investment value. For seacoast installation and places where atmospheric conditions have a corrosive influence on metals, Series 26 all brass operator with monel metal or silicon bronze gear is recommended.

This operator is recommended for any casement installation demanding long life and trouble-free operation. It fits all outswung casement windows 15 inches wide or wider. It may be used on either right or left hand sash without any change whatever. It may be installed with either close or extension hinges. It is applicable for casement control above the stool or concealed below it, as illustrated on the left. Win-Dor construction of Series 26 operator is tolerant to the hardest usage which devices of this kind may be expected to receive. Worm and gear, and arm and channel action is smooth, self-cleaning and anti-freezing.

When casement window operator selection is based on comparative construction features and a recognition of quality in materials and workmanship, Series 26 operator

CATALOG DATA

No. 26, steel arm, channel, and housing; bronze worm and bushing; reversible; with No. 251 steel handle or No. 251B solid brass handle, 8 inches standard length.

No. 26B, all brass except steel gear segment.

No. 26BM, all brass with monel metal gear segment.

No. 26BX, all brass with silicon bronze gear segment; brass handles as above.

NOTE: Where handle supports are required for all handles exceeding 8 inches, No. 253B support brackets should be ordered.

SERIES 30 RECOMMENDATIONS

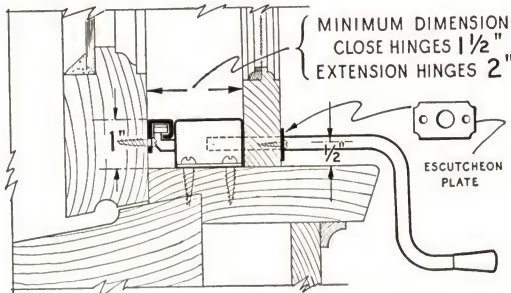

VERTICAL SECTION SCALE 3"-1"

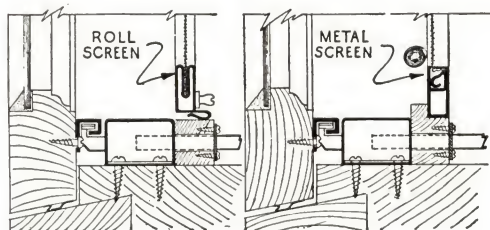

Above at the top is detail of typical installation for Series 30 operator, and below, the diagram illustrates use of wood filler strip where roll or metal screens are installed.

This operator is made to fit any casement window 15 inches or wider and is especially designed for narrow sills where clearances between screen and sash are required to be as little as possible. It can be used with either Win-Dor Series 76 close hinges or Win-Dor Series 75 extension hinges, or plain butts. When extension or cleaning hinges are employed, however, minimum of 2 inches is required between the sash and the outside surface of the screen. The 1 1/2-inch clearance referred to in the detail on the left requires the sash channel to be placed 2 3/4 inches from the jamb on the hinge side. In this position the case of the operator fits tightly against the attaching flange of the channel instead of in front of the channel, as shown.

CATALOG DATA

No. 30, steel arm, channel and housing; bronze worm and bushing; reversible; standard handle 8 inches for sills up to 9 inches wide. No. 251, steel, No. 251B, solid brass.

SERIES 35 OPERATOR

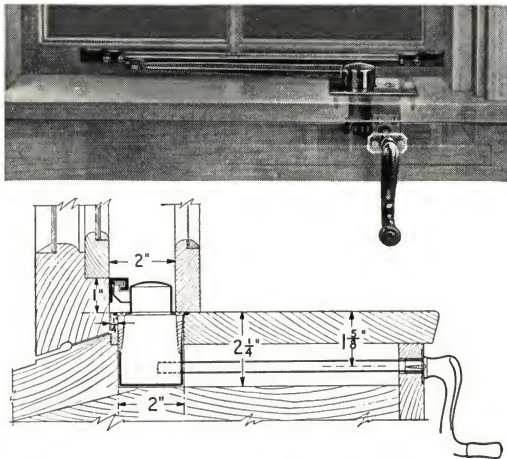

HALF-SURFACE OPERATOR

One of the finest operators available of this type. As illustrated, the mechanism is concealed below the window stool. For appearance and convenience this is an ideal arrangement because any type of screening may be used without interference and yet the operator itself is, at all times, accessible. Exposed parts are bronze with naval bronze worm acting on machined gear cut from silicon bronze. Extruded handles of desired length have square internal worm bearing, as illustrated on the right.

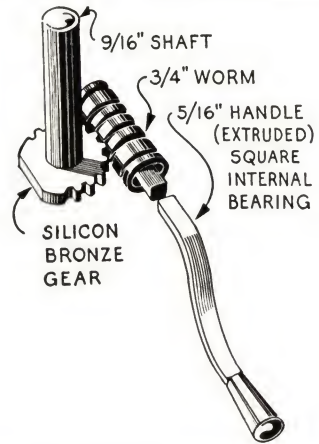

SERIES 29 OPERATOR

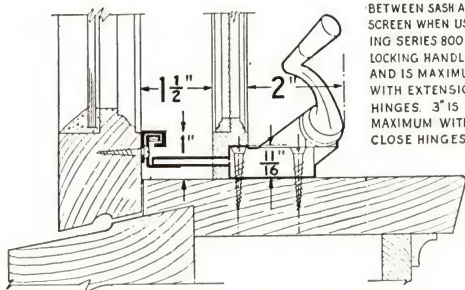

1 1/2" IS STANDARD BETWEEN SASH AND SCREEN WHEN USING SERIES 800 LOCKING HANDLE AND IS MAXIMUM WITH EXTENSION HINGES. 3" IS MAXIMUM WITH CLOSE HINGES.

VERTICAL SECTION SCALE 3"=1"

ANGLE DRIVE OPERATOR

This operator is constructed with housing and handle of die-cast zinc or cast bronze and arm and channel of steel. The driving worm of naval bronze operates against machine cut gear. Square steel handle shaft has strong internal worm connection. The arm and patented Win-Dor channel are similar to other Win-Dor operators but this type is **not reversible**. Detail on the left shows installation dimensions and clearances with either close or extension hinges.

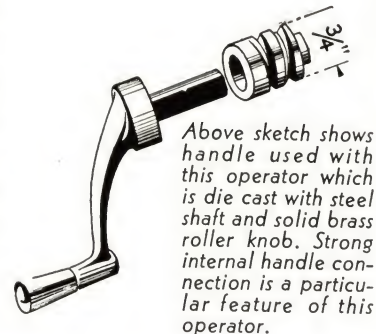

SERIES 61-65 STAY

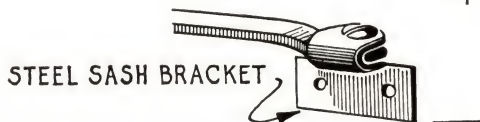
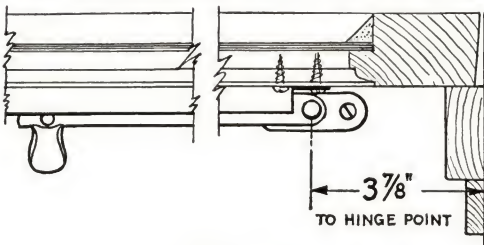
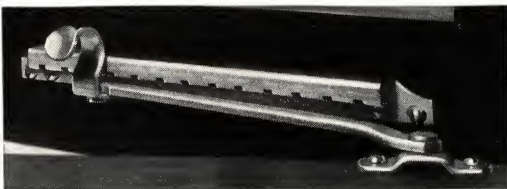

CASEMENT STAY

This is a simple, positive, automatic, **non-friction** device affording one-hand operation at low cost. The Series 65 Stay is reversible and applicable to either right or left hand windows by simply taking off the finger lift and turning it around on the arm. Operation is obtained by lifting the arm up into the channel and when it is released, the window is positively locked by arm being held in channel notches. The stay may be used on either wood or steel sash as indicated.

Illustration on the right shows operation and reversibility of finger lifts. On the left is bracket used for steel sash installation.

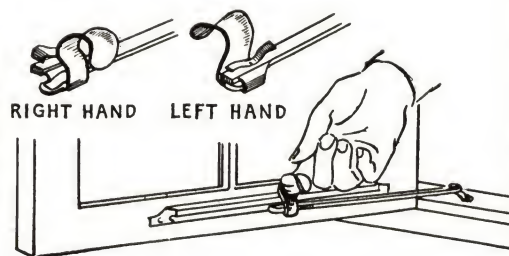

RECOMMENDATIONS

CATALOG DATA

• For monumental buildings, for government and institutional work, and for the finest residences where quality is the first consideration in specifying hardware, Series 35 operator will meet all requirements. As the mechanism is concealed below the stool, Series 35 operator is the choice of many architects where unobtrusive hardware installation is desired to conform with carefully detailed window trim. Series 35 operator is especially recommended for building locations which are exposed to seacoast atmospheric conditions where the attack of salt air would be disastrous to hardware of this type made from other than non-ferrous metals.

No. 35B, all brass and bronze operator with silicon bronze gear segment; reversible.

Standard handles, **No. 251B**, all brass, 8 inches as in drawing or **No. 252B**, ornamental cast bronze as in operator illustration.

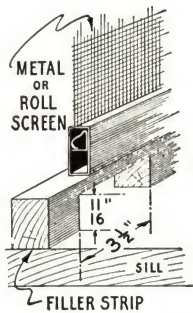

• While this operator will provide casement control on a wide range of installation details, it is primarily designed for wide stools. When used with metal or roller screens a strip is employed, notched as indicated on the left. This fills in the space on each side of the operator below the top of the case upon which the screen may rest. Series 29 operator is also made with a base plate or case adaptable for easy installation on stools of marble, tile, slate, etc. Win-Dor Series 29 operator is recommended where removable handle extending over the stool is not desirable.

No. N-29Z, die cast zinc housing and handle. Steel arm and channel. Bronze worm. Not reversible, specify right and left from inside. Fixed handle.

No. N-29B, all brass housing and handle. Bronze worm, steel arm and gear.

No. N-29BM. Same as N-29B except monel metal arm and gear.

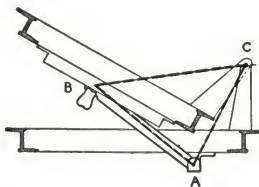

• The Win-Dor casement stay is recommended for use on all wood or steel casements 12 inches wide or wider hung with standard butts. It is not a substitute for through-screen geared operators, but is a convenient locking and holding device where screening is unimportant. Being non-friction, one-hand operation is a convenient feature. The diagram (upper left) shows the Win-Dor truss, the principle on which the casement stay is built. The lock takes hold at "B" and forms with the pivot "A" and the hinge "C" a rigid truss support to hold the casement in position against practically any wind force. Below is a typical detail of Series 61 steel casement installation.

No. 61C, for steel sash. Steel arm and channel, cadmium plated. Not reversible.

No. 61B, for steel sash. Solid brass. Not reversible.

No. W61C, for wood sash. Same as No. 61C except wood sash bracket is supplied. See installed view on page 5. Not reversible.

No. W61B, for wood sash. Solid brass with bracket same as No. W61C. Not reversible.

No. 65, steel arm and channel cadmium plated. Reversible. For wood sash only.

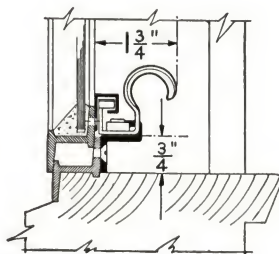

SERIES 76 HINGE



DESCRIPTION AND CATALOG DATA

CLOSE HINGE A universal casement hinge featuring corner reinforcement on the sash as illustrated. Projection only $\frac{3}{4}$ inch from sash surface. Frame leaf mortised. Strong rigid construction withstanding 200 pounds downward pressure per pair with 12 inches of reinforcing surface (see installation details below).

No. 762, steel, (double cadmium plated) corner reinforcing close type with brass washers, bronze bushings and loose pin, one pair to sash.

No. 762B—All brass.

No. 763, steel, (double cadmium plated) corner reinforcing close type friction hinge with adjustable friction knuckle.

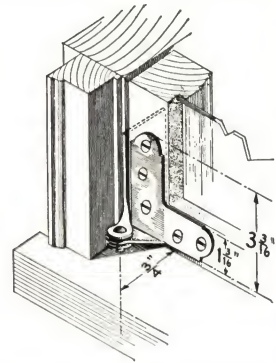

SERIES 75 HINGE

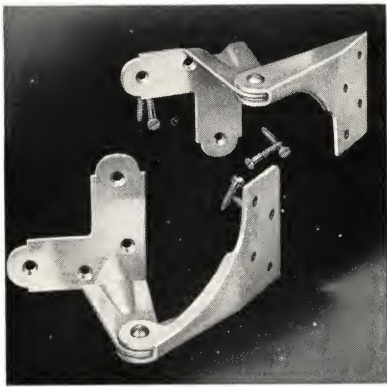

EXTENSION HINGE For purposes of cleaning this hinge throws the sash away from the frame sufficiently for 4 inches of cleaning space. Corner reinforcing type, (12 square inches bearing surface on sash per pair). Furnished for straight or beveled frames with loose pin or friction knuckles. Hinge projection $2\frac{3}{4}$ inches beyond frame.

No. 752 extension hinge, steel, double cadmium plated, bronze bushing, brass washers and loose pin.

No. 752B extension hinge, silicon bronze with bronze bushing.

No. 753 extension hinge, steel double cadmium plated with adjustable friction knuckle.

(See installation details below.)

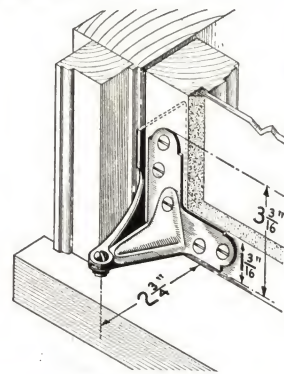

SERIES 70 HINGE

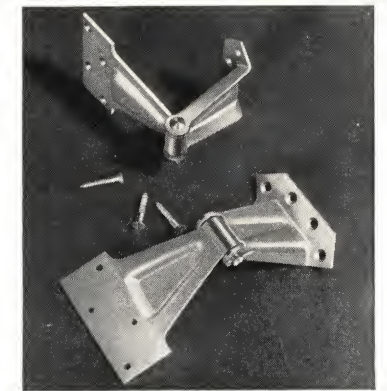

EXTENSION HINGE These hinges are also of the cleaning type. Have the same projection as Series 75 and are half-surface, the frame leaf being mortised and the sash leaf attached to the outside of the window stile. This hinge is especially recommended where extra center hinge is desired on exceptionally high and heavy casements as an auxiliary hinge to Series 75 corner reinforcing hinges. (See installation details below.)

No. 70 steel extension hinges, loose pin, bronze bushing.

No. 70B—All brass.

No. 701 steel center hinge for sash over 5 feet in height.

No. 701B—All brass.

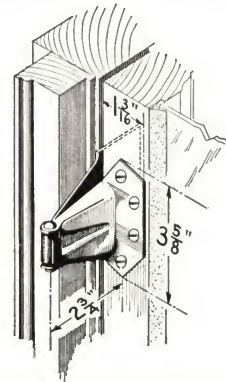

WIN-DOR HINGE INSTALLATION DETAILS

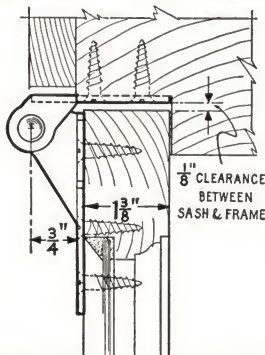

These drawings are installation details of Win-Dor hinges. On the left is a horizontal cross section showing attachment of Series 76 close hinges. Note minimum projection from sash.

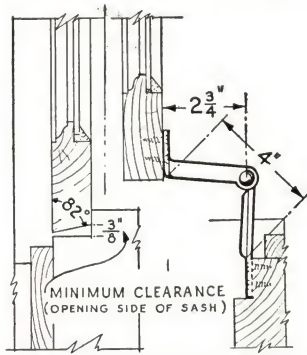

On the left are installation details for Series 70 hinges, showing sash bevel required. On the right is detail for Series 75 hinges. Both of these hinges provide 4 in. of cleaning space as indicated.

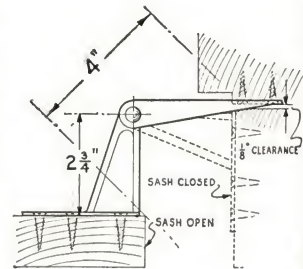

THE CASEMENT HARDWARE CO.

SERIES 800 LOCKING HANDLE

DESCRIPTION AND CATALOG DATA



This is a simple, well designed manual locking handle for wood casement windows. Illustration shows the case of steel, cadmium plated, bronze handle and keeper.

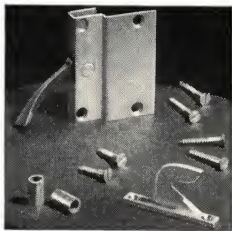

Where Venetian Blinds or other sun shades are used, this locking handle can be furnished in special design to avoid interference—as illustrated on the left.

Wherever manual locking of screened wood sash is desired this handle offers complete convenience as it is mortised into the window stop and works around the screen, closing the window for tight weathering without the inconvenience of screen removal. The drawing on the right illustrates the method of installing Series 800 locking handle. This device can be used wherever the dimensions of the screen (or window stop) conforms with the measurement shown. This type of stop is standard and generally milled out in one piece.

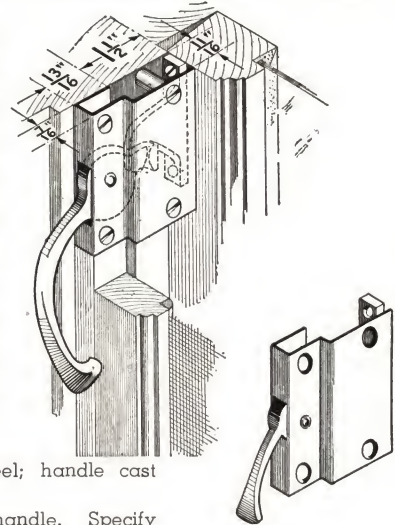

- No. 800A** housing and keeper, steel; handle cast bronze. Specify hand.
- No. 800B** all brass, cast bronze handle. Specify hand; housing steel; handle and keeper cast bronze.
- No. 803A**—same as 800A (short handle).
- No. 803B**, all brass (short handle).

SERIES 45 TOP CLOSER

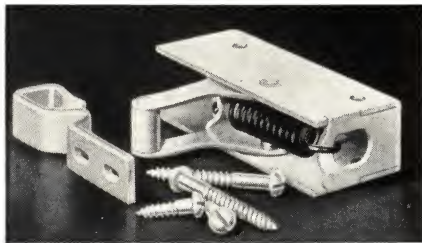

This easily installed device, which fits unobtrusively on the top corner of the window frame, engages the casement about 1 inch away from the window stop and pulls in the top of the sash automatically. It is a simple spring device for use on casement windows, screen and storm doors, closet and cupboard doors (eliminating narrow lock sets and catches) astragal doors, etc.

On the right is a diagram showing installation dimensions of Series 45 top closer. The case of the unit is attached to the upper corner opposite the hinge side of the sash. The window or screen stop is not indicated but it is usually cut and fitted to butt the case on the bottom and at the end, making an unobtrusive and neat installation.

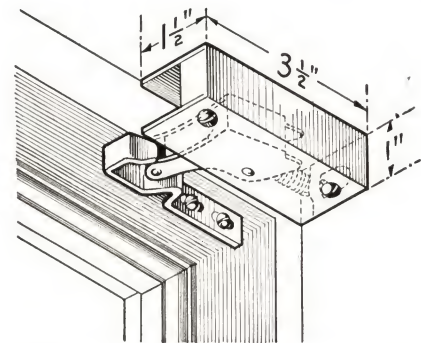

When sash are thrown open the keeper fastened to it automatically throws pulling lever over dead center tensing spring. In closing the full strength of the spring is, therefore, utilized to bring sash snugly into the opening.

- No. 45**, steel, cadmium plated case and keeper.
- No. 45B**, all brass with steel spring.

SERIES 81 SCREEN HARDWARE

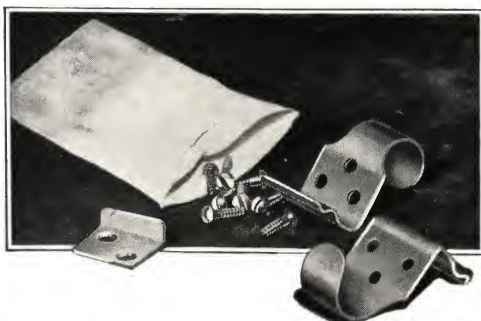

As illustrated on the right, Series 81 screen hardware is a simple arrangement of spring clips and a holding plate used for holding inside wood frame screens for outswung casement windows. The screen frame is mortised 3/16 inch deep about half way up from the bottom to receive the two spring clips. One of these is screwed to each side of the frame. Opposite them in the window frame, are driven round head screws. At the top of the frame the angle plate is fastened. The screen is slipped behind it and snapped over the side screws which hold it firmly in place.

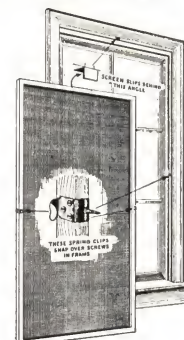

Series 81B, all brass screen hardware. One set to a screen.

THE CASEMENT HARDWARE CO.

SERIES 28 OPERATOR

**FOR LIGHT AND INTERMEDIATE
STEEL CASEMENTS**



An under-side view of Series 28 operator showing how the case has an extended apron making the base of the operator flush and snug-fitting on the window stool.

Fine materials, fine workmanship, and fine appearance combine to make the Win-Dor Series 28 the quality operator for steel sash. It is adaptable to all makes of steel windows and may be obtained from any window manufacturer upon specification, assuring architect, builder, and owner trouble-free casement operation.

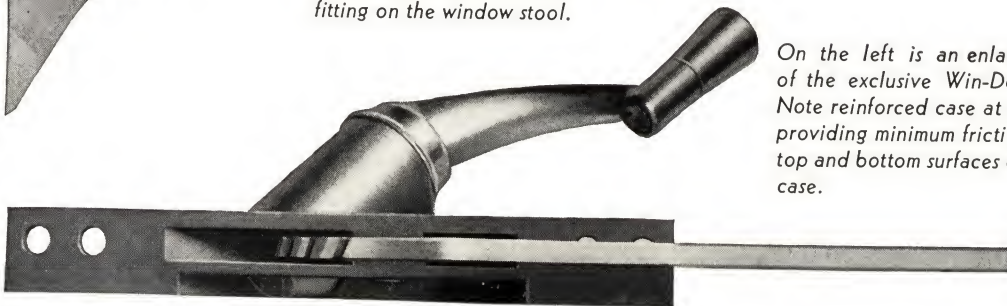

On the left is an enlarged illustration of the exclusive Win-Dor arm bearing. Note reinforced case at point of contact providing minimum friction area on both top and bottom surfaces of arm within the case.

- 1. Here is shown the big rustless over-sized $\frac{3}{4}$ -inch naval bronze precision worm gear.
- 2. Rigidly reinforced arm pivot. In the Win-Dor operator the arm moves between bearing projections in the housing. At this critical point extra strength is needed.
- 3. Oversized square handle seat. The operator handle has a $\frac{5}{16}$ -inch squared steel shaft internal worm connection.
- 4. Extra strong to stand over-rated strains. The arm of the Win-Dor operator will withstand a straight pull equal to a weight of over 150 lbs. at the end of the arm.
- 5. Flush base hugs the sill. No projection, no dirt pocket, no notching.

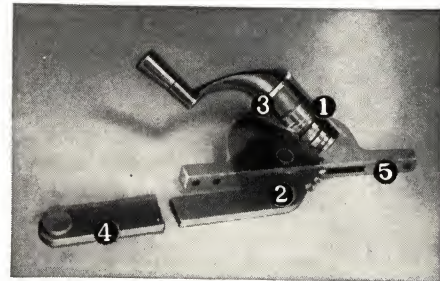

MATERIALS AND FINISHES

Win-Dor Series 28 operators are made in an unusually complete range of materials and finishes which may be used to maximum advantage in every climate and to fit any appropriation. Thus in every case individual preference in decorative effect may be obtained to secure harmonious and attractive installation whether in standard hardware finishes or combinations in colorful enamels.

No. 28Z operator—Die-cast housing and handle from virgin zinc alloy (A.S.T.M. XXIII) under high moulding pressure according to proven technique. Steel arm and channel heavily cadmium plated. Housing and handle enamel, plated or combination.

No. 28B—Same as No. 28Z except cast bronze housing and crank. Sheet brass channel. Standard finish statuary bronze or finished to specification.

No. 28BM—Same as No. 28B except monel arm and gear. Finished to specification.

At the right is a diagram showing installation measurements for Series 28 steel casement operator. The case is adjustable for attachment to all standard makes of steel casement windows.

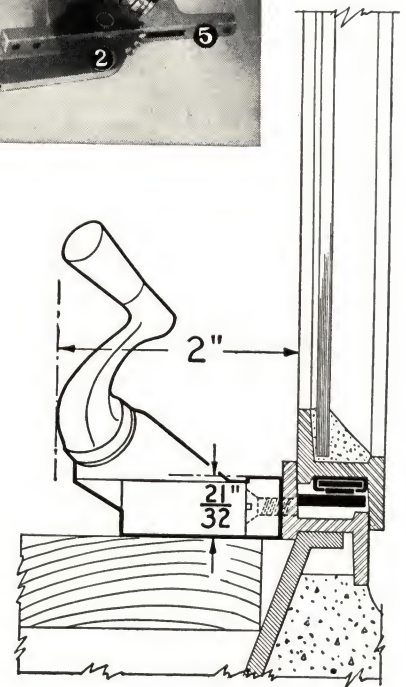

THE CASEMENT HARDWARE CO.

SERIES 32-33 OPERATOR

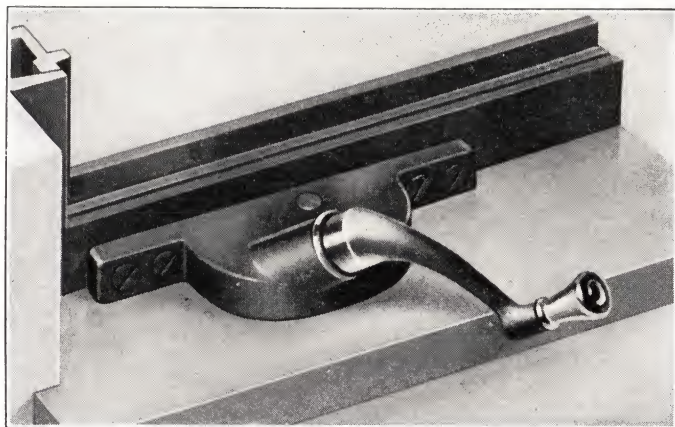

FOR OVERSIZE AND HEAVY STEEL CASEMENTS

This solid brass heavy duty steel casement operator is adaptable to intermediate and heavy section casements of any size where strong operating hardware is essential. Larger throughout, this new heavy operator has nearly twice the strength and power of standard operators.

Recommended for all heavy casements and intermediates beyond standard size limits.

No. 32B—Operator for steel sash. Solid brass case and handle. Hardened steel arm with extruded brass sliding lock end piece. Finished to specification.

No. 32BM—Same as 32B except Monel Arm and Gear. Finished to specification.

Handle designed with larger grip and increased power. Note 2 1/4" radius of swing of handle.

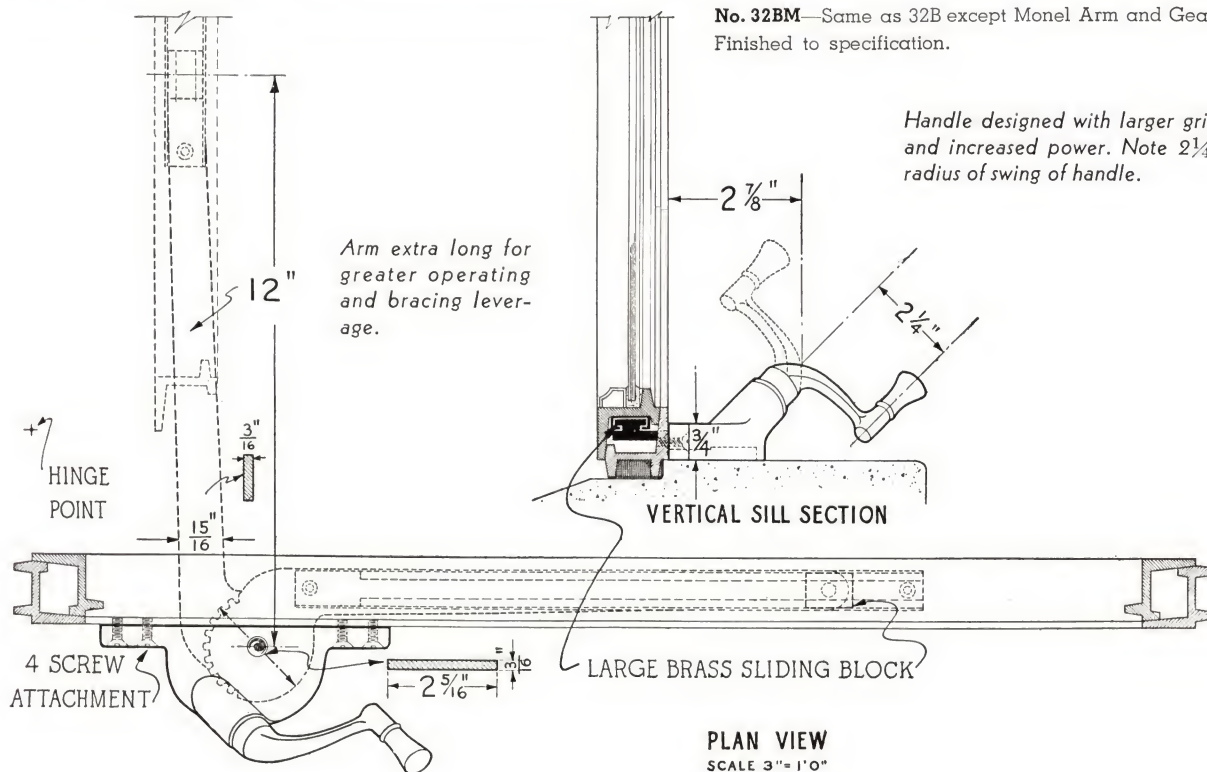

FOR LARGE SIZE WOOD CASEMENTS

This operator having the same construction feature as Win-Dor No. 32B described above, is for large size wood casements where hardware is subject to particularly heavy use and abuse. Like Series 29 operator described on page 5, the case is made with flush base. It is provided with four screw attachment on stool.

No. 33B Operator—Operator for Wood Sash. Finished to specification.

No. 33BM—Same as 33B except Monel Arm and Gear. Finished to specification.

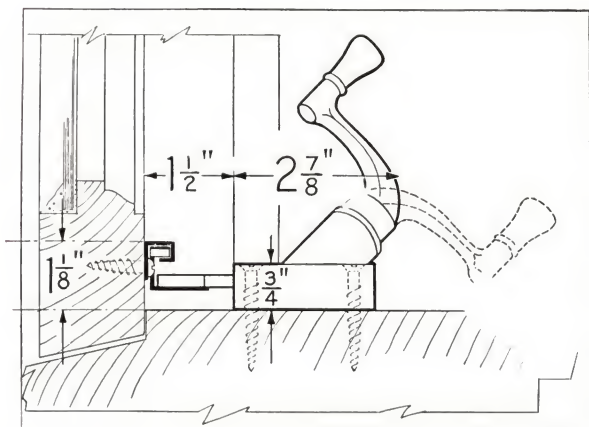

WinDor

C A S E M E N T H A R D W A R E C O M P A N Y



Digitized by ASSOCIATION FOR PRESERVATION TECHNOLOGY, www.apti.org for the
BUILDING TECHNOLOGY HERITAGE LIBRARY
<https://archive.org/details/buildingtechnologyheritagelibrary>

T